

---

# OVIDE SMART ASSIST 4 USER'S MANUAL

---

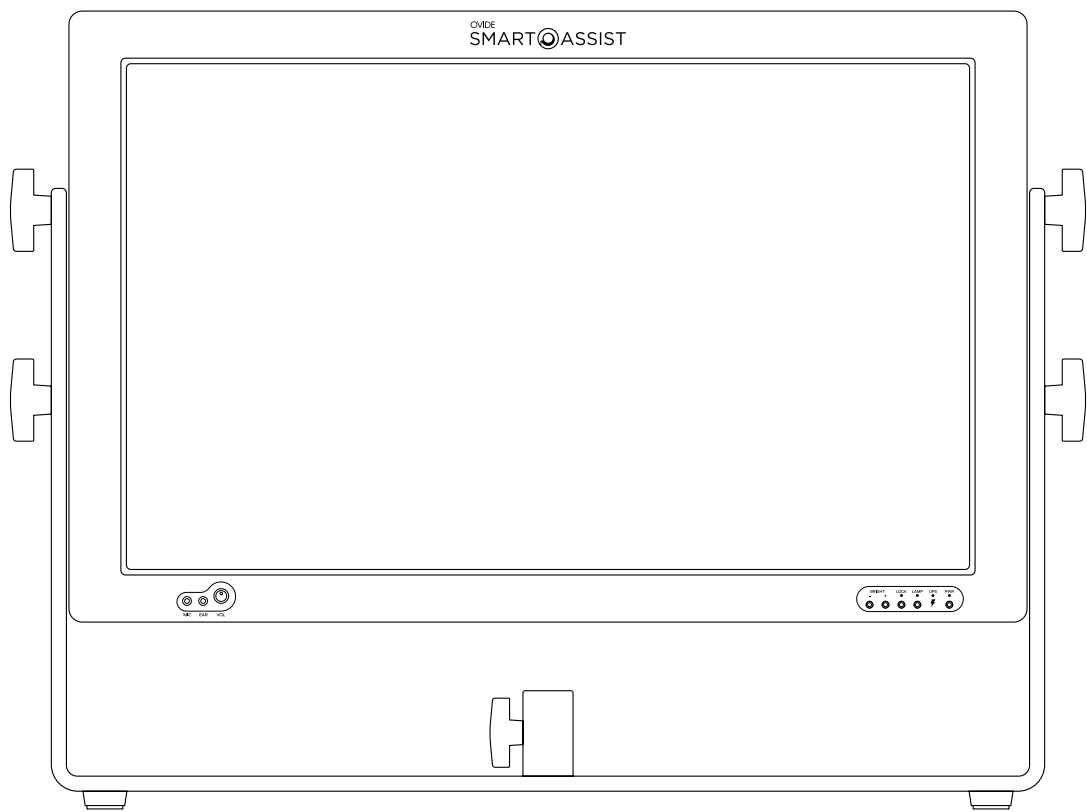

<a href="#">Important information</a>	3
<a href="#">Installing the QTake® USB dongle</a>	6
<a href="#">Location and function of parts</a>	7
<a href="#">Control panel</a>	10
<a href="#">Physical dimensions</a>	11
<a href="#">Utils in dock</a>	12
<a href="#">Desktop folders</a>	12
<a href="#">Settings</a>	12
<a href="#">Understanding video &amp; audio delay</a>	14
<a href="#">Special qtake functions for Smart Assist 4</a>	14
<a href="#">Understanding video processing</a>	14
<a href="#">Video routing</a>	15
<a href="#">Accessing system's RAM modules</a>	17
<a href="#">Changing your video drive</a>	19
<a href="#">Trouble shooting</a>	19

**⚠ PLEASE TAKE ALL NECESSARY PRECAUTIONS WHEN USING THE SMART ASSIST<sup>®</sup>, AND PAY SPECIAL ATTENTION TO:**

## **Batteries and power supplies**

Please always use professional video batteries and avoid home-made ones. Professional video batteries are meant to give excellent performance, and what is most important, to be safe. Always avoid to short-circuit the battery connections that can cause current to flow which can damage the cells and even pose a fire hazard. For example, you should not carry batteries in a bag or pocket where they may contact other metal objects.

Smart Assist 4 has an internal battery used for the internal UPS.

Batteries, power supply and cables must be kept away from water and moisture. Always unplug from mains socket when not in use.

Before cleaning the Smart Assist<sup>®</sup>, unplug any external power source and remove batteries from their socket.

**Smart Assist 4 can draw upto 280W. Please make sure you use batteries and power supplies that meet this requirement to avoid damage to the batteries and to this unit.**

## **Using Smart Assist<sup>®</sup> safely**

Smart Assist<sup>®</sup> is a heavy unit and therefore special care has to be taken when moving it around.

Always try to move it around inside its transport case.

- Never block any of the ventilation holes. It may permanently damage the unit and void the warranty.
- Always make sure that the Smart Assist<sup>®</sup> is mounted securely and is unable to fall onto anyone nearby. This is especially important when mounted on a C-Stand or Magliner<sup>®</sup> pin.
- Always ensure that cable runs to the Smart Assist<sup>®</sup> are clearly visible and do not present a trip hazard.
- Do not place on uneven or unstable surfaces.
- Do not touch the Smart Assist<sup>®</sup> screen with sharp, metallic or abrasive objects as you may damage the screen surface.
- Do not expose to strong electrical or magnetic fields.
- Do not expose to or use near liquids, rain or moisture.
- Do not dispose Smart Assist<sup>®</sup> or its batteries in waste and do not incinerate it, but follow local regulations for safe disposal.
- Do not use the stand by cover when the unit is on or hot.
- Make sure that right polarities and voltages are used.

## Notice

Copyright© 2016 Ovide Maudet S.L.<sup>®</sup> ('referred to as Ovide<sup>®</sup>'). All rights reserved. All information in this document is subject to change without notice. No part of the document may be reproduced or transmitted in any form, or by any means, electronic or mechanical, including photocopying or recording, without the express written permission of Ovide<sup>®</sup>. A reference to Ovide<sup>®</sup> includes its related entities, subsidiaries and parent company.

## Trademarks

Ovide®, Smart Assist® and Ovide Smart Assist® as well as Ovide® and Smart Assist's® logos are registered trademarks of Ovide®. QTake® is a registered trademark of In2Core SRO. Arri® is a registered trademark of Arnold & Richter Cine Technik GmbH & Co®. Apple®, Apple's® logo, FireWire®, iPod®, iPod Touch®, iPad®, iPhone®, OSX®, iOS®, Mac® and Macintosh® are registered trademarks of Apple Inc®. Final Cut Pro®, QuickTime® and the QuickTime® logo are trademarks of Apple Inc®. Adobe Premiere® is a registered trademark of Adobe Systems®. Philips® is a registered trademark of Koninklijke Philips NV®. Avid® and DNxHD® are registered marks of Avid Technology Inc®. Lemo® is a registered trademark of Lemo S.A®. Fischer® is a registered trademark of Fischer Connectors Inc®. AnyDesk® is a registered trademark of Philandro Software GmbH®. IDX® is a registered trademark of IDX Technology Europe Ltd®. Bebob® is a registered trademark of bebob factory GmbH®. All other trademarks are the property of their respective holders.

## International Hardware Limited Warranty

Ovide® warrants that:

- The main product, not including any external accessories, will be free from defects in materials and workmanship for a period of 1 years from the date of purchase, the user may upgrade to a total 2-year warranty at the time of purchase, with an extra cost.
- This warranty is exclusively for the benefit of the original purchaser and is not assignable or transferable.
- If during the warranty period, the product is shown to be defective Ovide® may at its option:
  - A) Replace the goods or supply equivalent ones
  - B) Repair the goods
  - C) Pay the cost of replacing the goods or of acquiring equivalent ones
  - D) Paying the cost of having the goods repaired

The customer must notify Ovide® of any defect in the goods in writing prior to the expiry of the warranty periods set out above. The customer will be solely responsible for returning the goods to Ovide®. Upon acceptance of a warranty claim by Ovide®, where Ovide® repairs or replaces the goods, it will be responsible for reasonable shipping costs incurred in sending the goods to the customer. The customer is responsible of either having an insurance or pay the couriers insurance.

## Warranty Exclusions

This warranty applies only to defects in workmanship and does not cover defects caused by:

- Neglect
- Improper or negligent acts or omissions
- Unauthorised repairs or attempted repairs
- Tampering with or modification of the goods
- Connection to incompatible equipment or power sources
- Exposure to water or weather
- Exposure to magnetic fields or corrosive liquids or substances
- Physical damage
- Warranty will be automatically voided if any of the warranty seals are removed or have been tampered.



Except as stated in this warranty, Ovide®, its vendors, agents, resellers and distributors disclaim in their entirety all other warranties, express or implied, including without limitation all warranties of merchantability or fitness for a particular purpose. The remedies outlined in this warranty are the exclusive remedy a customer has arising from defective goods which are subject to the warranty. Ovide® does not warrant that the goods will operate in a manner which is error free or uninterrupted. The goods are not intended to be the primary or only data storage device for data – customers are solely responsible for back up and protection of data.

# IMPORTANT INFORMATION



Thank you for choosing the Ovide Smart Assist®: your all-in-one hardware for video assist. It's the most video assist compact solution for QTake® available, with long battery life and a high-resolution screen.

With a wide range power input (from 18 to 30vdc), three power inputs and hot swap capabilities, Smart Assist® is great for rapid on-site video assisting.

Your Smart Assist® comes pre-configured to run optimally QTake®. Both OSX® and the hardware have been optimized. Therefore, we recommend not changing any system settings or installing any OSX® updates unless Ovide® or In2core® tell you to do so.

Hard drives inside: System disk is only for apps and system. Data disk is only for video.

# INSTALLING THE QTAKE® USB DONGLE

If you are using a permanent QTake® license, you will have your license protected by a USB dongle similar to this:

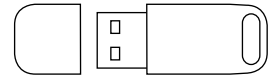

To avoid losing or damaging the dongle, there is a hidden USB 2.0 port beneath the unit where you can plug the USB dongle in a safe place.

## STEP 1

Remove QTake label from the dongle

## STEP 2

To insert the dongle, tilt the Ovide Smart Assist® towards you

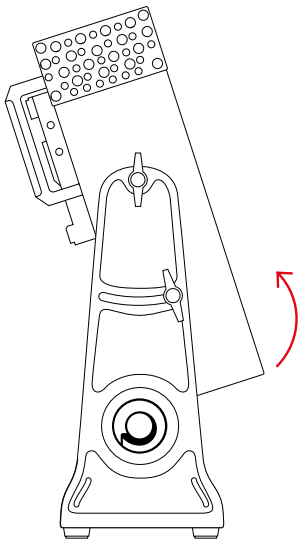

## STEP 3

Remove the two Philips PH® screws in the lower left corner and remove the cover

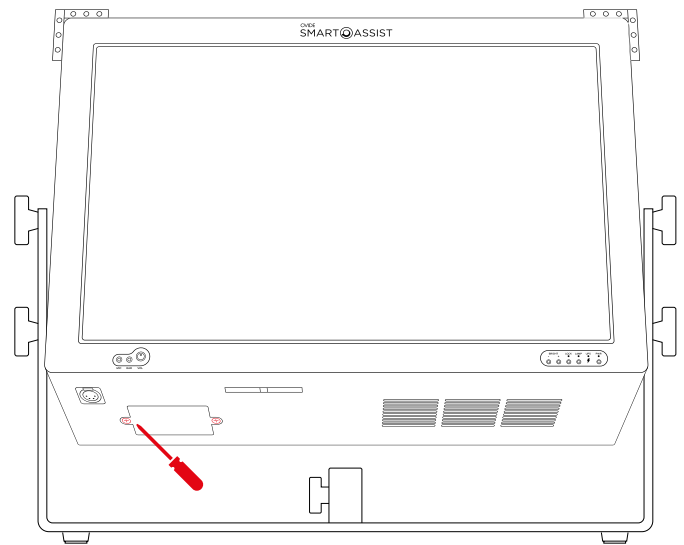

## STEP 4

Insert the dongle

## STEP 5

Put back the cover and the screws

## STEP 6

Restart the Ovide Smart Assist®. Now QTake® should detect the dongle, otherwise please read the troubleshooting section

# LOCATION AND FUNCTIONS OF PARTS

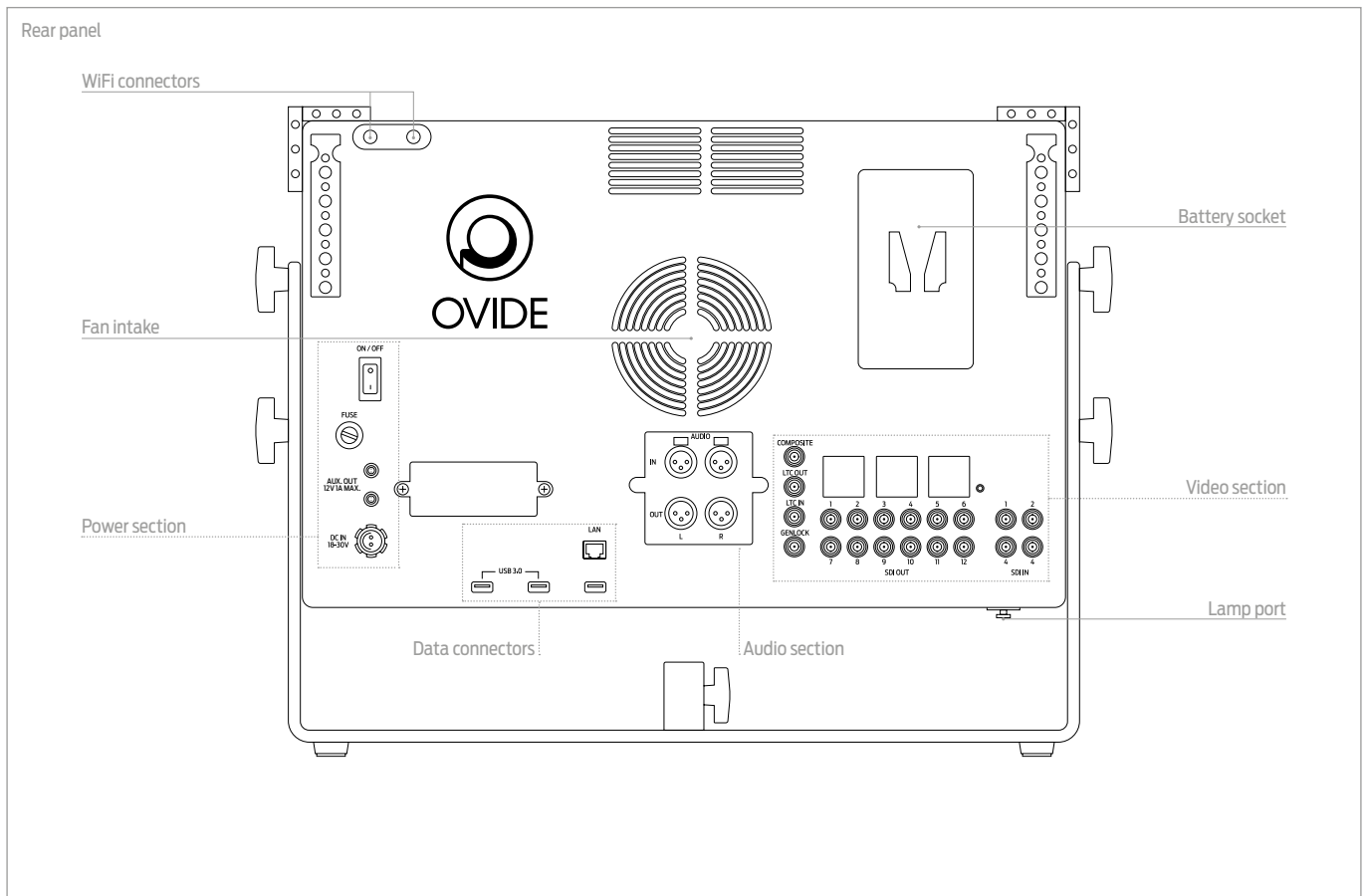

**Fan intakes:** This is the fan intake that blows air straight into the processor and GPU. Never block this airflow as it will permanently damage the unit and will void its warranty.

**Battery socket:** one battery sockets is provided.

**⚠ WARNING:** Due to the high processing power of this unit, there is an extreme demand of current to the battery. Only Bebob High Load batteries (V-xxxRM) can be used, and due to their 20A limit, recording options are limited to ProRes LT when using 4 cameras or 4K when V lock batteries are used. When using power supply, good block batteries or internal UPS, this limit does not apply.

**Lamp port:** Use this port to insert a gooseneck LED reading light. **Please note this is NOT a standard XLR4 power output.** Do not connect regular gooseneck halogen lights, as it will overload the output.

**Wifi connectors:** Two SMA connectors in the back of the unit allow you to put Wifi antennas, plus there is a dual Bluetooth/ wifi antenna in the top right corner of the screen. Be careful not to cover them to avoid losing signal and avoid having cell phones or any other transmission devices close to them.

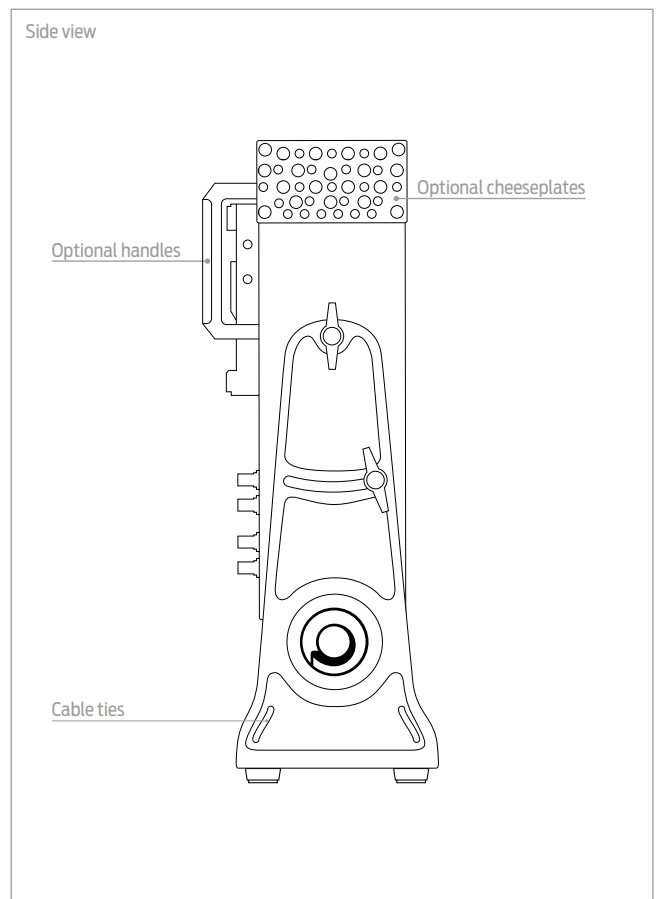

## POWER SECTION

There are three power inputs, and only one of them is needed to run Ovide Smart Assist®. Any available power source will be used, it will hotswap to any available input. System will always choose the highest voltage available.

This unit is equipped with an internal UPS that will let you run the unit for two minutes without any power source. If the unit is on and no power sources are available, a 2-minute countdown will start and UPS LED will start blinking orange. Once the 2-minute countdown finishes, the unit will immediately shut down, so make sure to either provide a power source on time, or do a proper OSX® shutdown before the UPS countdown is over.

**Main power button:** This button will immediately shut down the system if you switch it off, so make sure that OSX® is shut down before using this switch. If you turn this switch off, there will be no power consumption at all. If you turn it on, but do not turn on the front button, unit will be in standby mode, in which only the fans run and UPS is in charge mode. In standby mode there is minimal power consumption, but be careful as you may run your battery out of power if you leave the unit in standby mode for several hours.

**Fuse:** This is the fuse protecting the unit. If fuse blows out, make sure that the power supply is of the right voltage (18-30vdc), it is of the right polarity and that the unit is not wet or humid. Once sure that everything is OK, proceed to change for a new fuse.

**Auxiliary outputs:** They use the same Lemo® connectors as Arri® cameras and they are 12v regulated (always 12v, provided the input voltage is within accepted range). These outputs are current limited. If you connect something that draws too much power, it will shut the outputs down to avoid shutting down the whole system.

**Power input:** This is the standard Fischer® 24v connector used to dc power Arri® cameras. Use this connector to power the Swmart Assist® from external sources. You can use any external DC source between 18 and 30v.

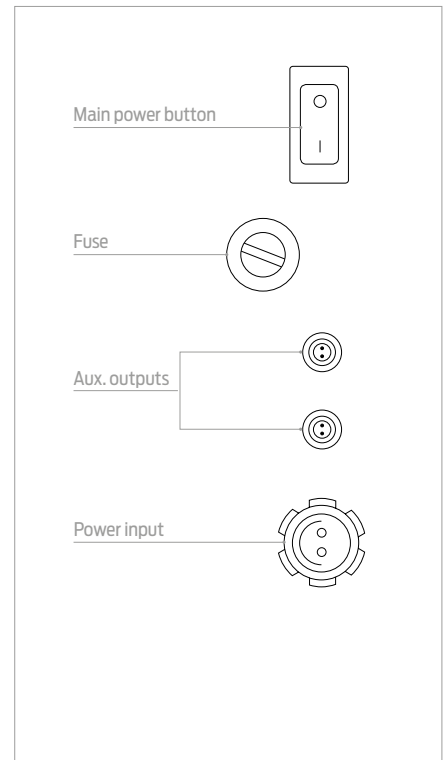

## DATA CONNECTORS

**USB 3.0 & 2.0 ports:** Use these ports to connect any OSX®-compatible devices, such as hard drives, keyboards or mouse.

**Ethernet connector:** Use this port to connect Ovide Smart Assist® to a wired network.

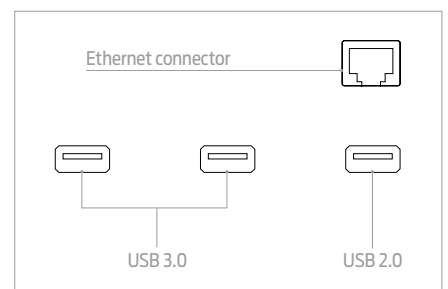

## AUDIO SECTION

**Analog audio inputs:** These are professional balanced audio inputs. In QTake®, they will be named 'XLR analog input'

**Analog audio outputs:** These are professional balanced audio outputs. All outputs (audio, video, tc) are always active, regardless of the inputs used.

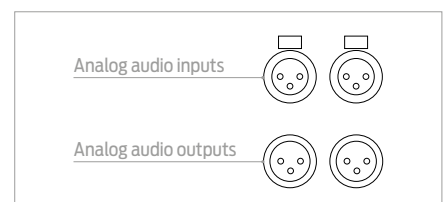



## VIDEO SECTION

**SDI inputs:** These are inputs 1 through 4, they are SDI, HDSDI and 3GHSDI capable. These inputs are fully independent both in sync and format (e.g. one input can be 625/50i and the other 1080/29.97p and work simultaneously).

**SDI outputs:** These are outputs 1 through 12, they are SDI, HDSDI and 3GHSDI capable. These are fully routable and their OLED displays will let you know what is routed to each output. Please go to page 15 to understand QTake's routing menu.

**OLED displays:** These OLED displays will inform you what has been routed what is the feed in each of the 12 outputs. It will tell you the name this output has been given in QTake®, its video feed (Live, Processed, Multiview...).

**OLED on/off button:** Press this button to turn on/off the OLED displays.

**Composite output:** This BNC connector can be setup as a downconverted version of one of the 4 video processors (Please go to page 15 to understand QTake's routing menu) provided the input is in one of these formats.

**TC input:** Use this connector to input LTC timecode (Future use, not yet enabled).

**TC output:** This connector outputs LTC timecode (Future use, not yet enabled).

**Genlock:** Used to genlock the outputs of Smart Assist.

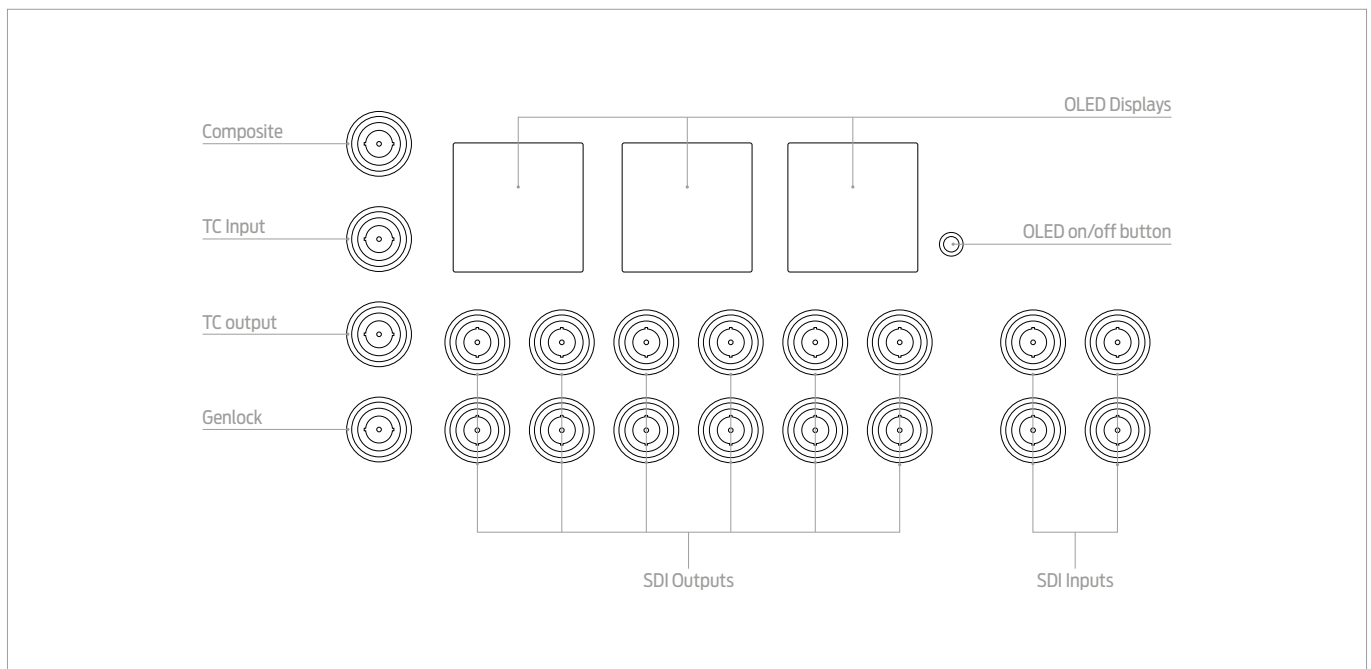

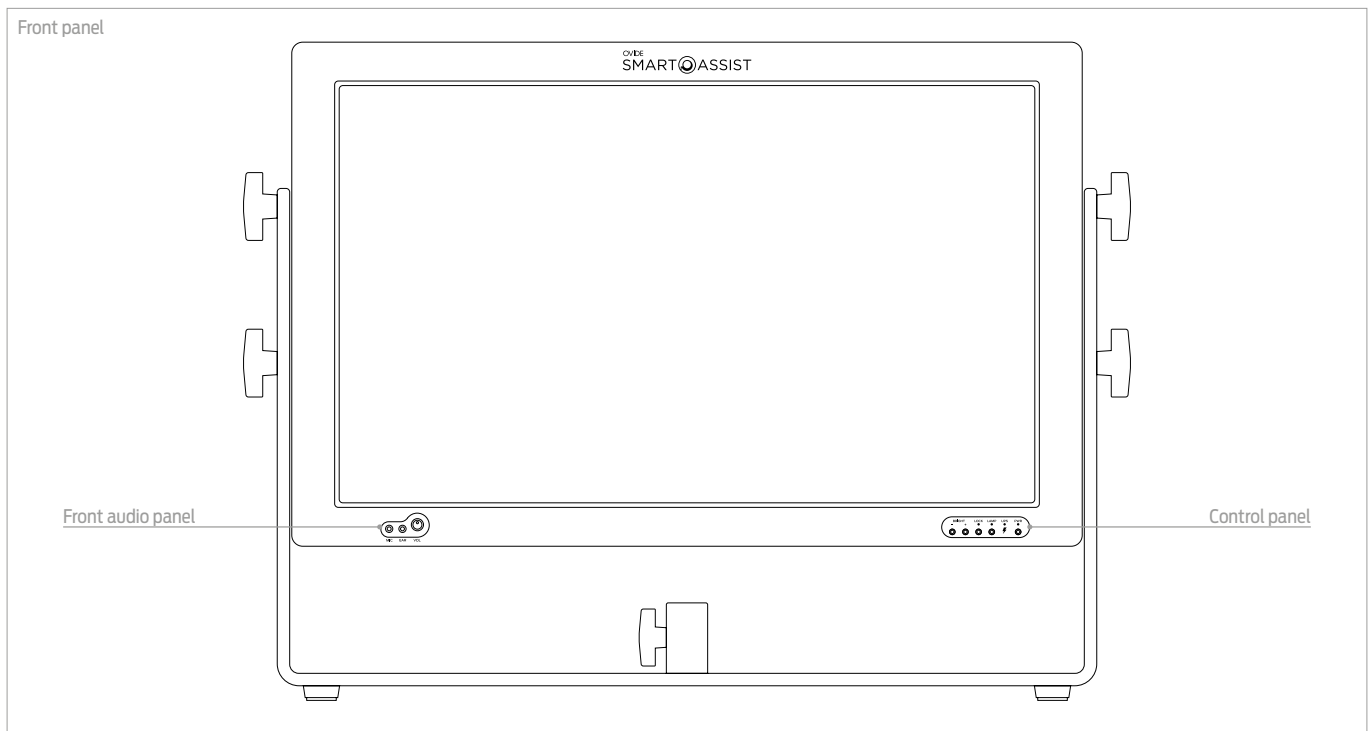

<b>Power button</b>		<p>Press to power on/off. Single press when unit is in standby (back power button on, front power lit orange) will turn unit on. When unit is on, pressing power button will ask OSX® to turn the system off. Please follow OSX® onscreen instructions to turn off. If OSX® is unable to shut down, you can do a long press (more than 3 seconds) of this button which will force a system shut down.</p>
<b>Power LED</b>		<p>Will be still orange when back power button is on and there is at least one valid power input available. In this situation, the fans are running and the UPS is charging. The rest of the components are in standby state. This mode of operation is useful to cool the system down during lunch breaks, etc.</p> <p>Will blink green while unit is booting and performing self test. If light does not keep still after a few seconds, there is a hardware issue, please contact support. When turning off, please wait for LED to become steady orange again before removing power or turning back power button off.</p> <p>Led will toggle orange/green if there is an internal power supply problem.</p>
<b>UPS LED</b>		<p>It has four states: still orange (UPS is charging), still green (UPS is fully charged and ready), blinking orange (no power sources are available and unit is running on UPS), off (there is a UPS malfunction). Right before UPS power is about to end (and unit turns off) LED will start blinking orange rapidly. Please shut down QTake immediately and OSX or provide a power source.</p>
<b>Brightness buttons</b>		<p>To adjust brightness, press + first and then +/- buttons to increase &amp; decrease brightness.</p>
<b>Lamp button</b>		<p>Use this button to turn on and choose color of the (optional) gooseneck lamp. Pressing will toggle between off, red (for dimmed environments) and white.</p>
<b>Lock button</b>		<p>Use to lock the touchscreen. All other functions such as external keyboard and mouse will still work. It will not interfere normal system operation, just disables touch options. Long press is needed both to lock and to unlock.</p> <p>Useful to clean the screen and not mess around QTake®. Also useful when moving the unit around.</p>
<b>Microphone input</b>		<p>This minijack connector is used as a source to the talkback system with iOS devices running QTake monitor app. Please refer to QTake®'s user manual for further info.</p>
<b>Headphone output</b>		<p>This minijack connector can be used for audio monitoring and/or the talkback system with iOS devices running QTake® Monitor App. Please refer to QTake®'s user manual for further info.</p>
<b>Headphone volume</b>		<p>Press it to let it stick out of the chassis and comfortably adjust the volume. Push it to put it back to the recessed position and avoid accidental volume changes.</p>

# PHYSICAL DIMENSIONS

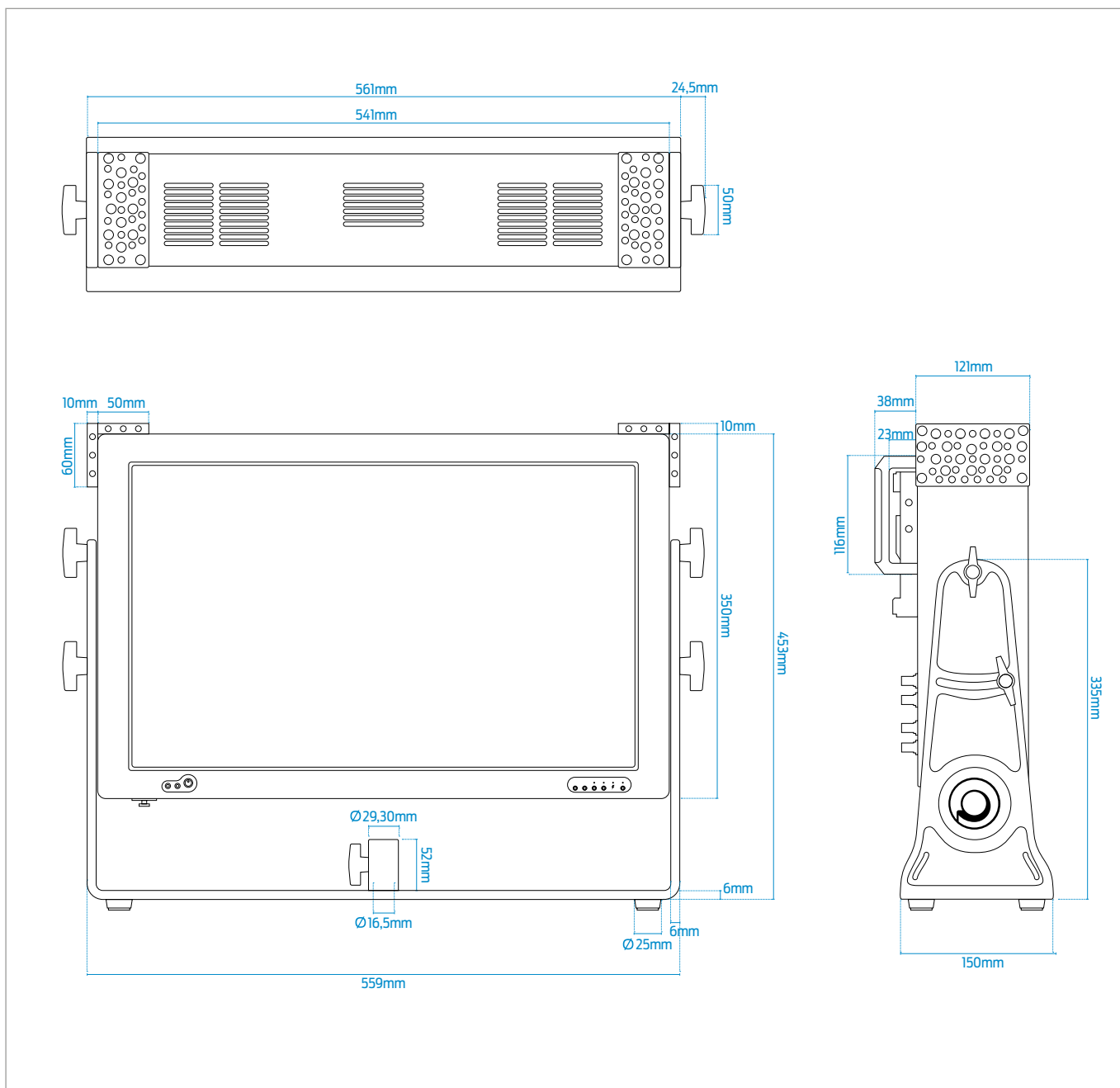

There is a folder in the dock called utils with the symbol and inside this folder you will find:



## AnyDesk®

With this app, any other person equipped with AnyDesk® will be able to remote diagnose and setup your system. Whenever you are connected to the internet (you may use your 3G/4G smartphone), Ovide® can provide remote assistance.



## HiTempMode

Ovide Smart Assist® is a computer and computers get hotter as processing needs increase. Under heavy processor loads, it is very important to cool the processor. This is why the rear fan intake must be kept clear and with sufficient space around your Smart Assist so that airflow is correct.

If the ambient temperature is high, your Smart Assist can have problems cooling. You will notice it with the CPU temp indicators in the QTake® status bar and messages alerting you of poor CPU performance. In this cases, you may want to lower the CPU speed to relief the heat inside. You will loose some CPU performance, so less video processing (e. g. LUTs, DVE, h264 recording...) will be available, but it will be much stabler for recording.

To enter HiTempMode, just open the Utils folder in the Dock and click the HiTempMode icon. It will reduce CPU performance until next reboot.

---

## DESKTOP FOLDERS

In Ovide Smart Assist®'s desktop you will find three folders:

**LUT:** Copy here any LUTs you want to use in Ovide Smart Assist®. Remember to restart QTake® if you copy files to this folder while QTake® is running, as otherwise they will not be detected.

**CDL:** Copy here any LUTs you want to use in Ovide Smart Assist®. Also, any CDL created in QTake® will appear in this folder. Remember to restart QTake® if you copy files to this folder while QTake® is running, as otherwise they will not be detected.

---

## SETTINGS

**Default password:** Default password in SmartAssist® is *Ovide*. You can change it if you wish. We didn't left a blank password because some programs require a password in the system account to work properly. Remember that if you haven't changed it, you can always use the password hint that will exactly tell you that the password is *Ovide*.

**Screen keyboard:** We advise you to use a screen keyboard so that you can work without any keyboard at all, even when using bare OSX®. To show it just open keyboard preferences, under OSX®'s system settings and choose 'show keyboard'. If you want to fully support screen keyboard, you will need to activate 'sticky keys' from accessibility under OSX®'s system settings. This way you can press several keys at a time (such as Cmd + W to close a window). Please remember that sticky keys also affects USB keyboard, so don't forget to disable it before using a USB keyboard.

**Doubleclick speed (Accessibility):** If your screen seems to doubleclick instead of single click or do long presses when you are just clicking, slow down the double click speed.

If you don't feel comfortable with the double click speed of your touchscreen, you'll need to slow it down (or speed it up) from OSX®. If there is no USB mouse connected, the OSX® control panel will not show any mouse options. Therefore it is better to open the control panel, choose accessibility, mouse and there adjust the double click speed.

**Headphones volume:** In OSX System Preferences, Sound, Output, set sound effects to Headphone port (to avoid them sound through XLR and SDI outs) and set output volume to maximum so you can then control headphones volume using front knob.

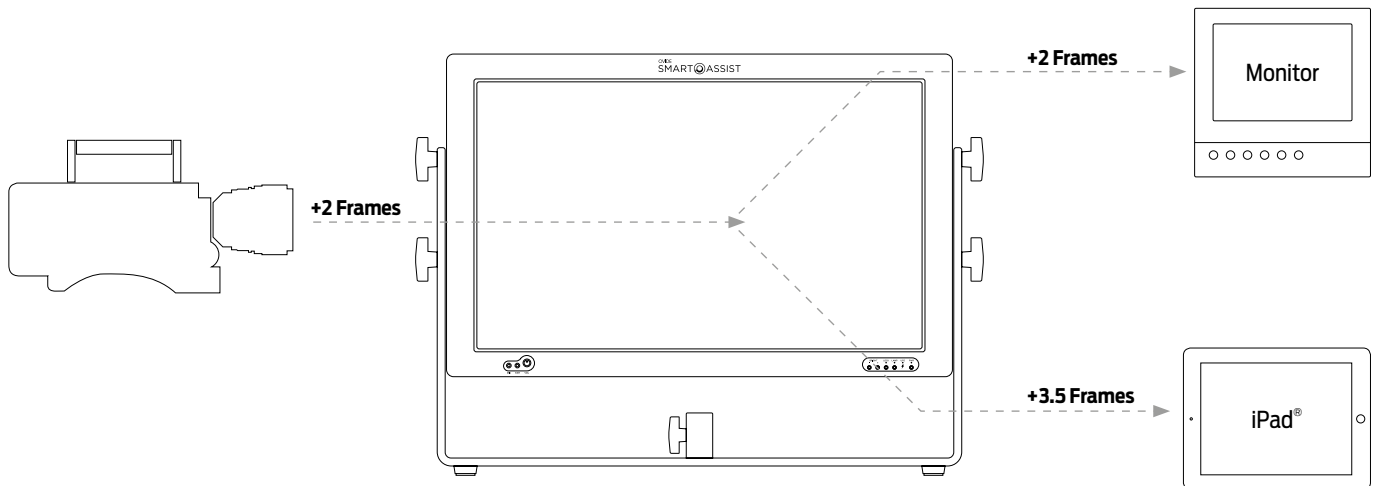

## VIDEO

**External monitor** (HDS DI & Analog): 4 frames of total video delay from video input. Embedded audio is completely in sync with its video.

**iPad®**: 3.5 frames of total video delay from video input. iPad®'s headphones output and builtin speaker's audio is completely in sync with its video.

## AUDIO

Analog out including headphones out delay:

**Audio input:** (Analog or HDS DI embedded): 2 frames of total audio delay by default to match the video delay in Ovide Smart Assist® screen. You can change this delay in QTake®'s project settings to match the delay in the video outputs adding 2 extra frames of delay to match video output.

**Zero delay mode:** There is also an option in QTake to work in Zero delay mode (E-E) when in live so that there is no audio delay from in to out.

## RECOMMENDED SETTINGS

**Reference monitor** ▶ **Analog output and/or headphone output**

Smart Assist® built in monitor must be in sync ▶ Set delay to 2 frames

External monitors must be in sync ▶ Set delay to 4 frames

Both monitors must be in sync ▶ Set delay to 3 frames. Both monitors will be slightly out of sync, but it will be hardly noticeable

## LOW DELAY MODE

If you set a processor manually to 59.94, you will have a lower delay in that processor, but some framerates will look a bit stuttering. This is a good output for 23.98 and 24fps. For other framerates, it will look stuttering.

# SPECIAL QTAKE FUNCTIONS FOR SMART ASSIST 4

Please remember to change QTake® preferences to enable customization for Ovide Smart Assist®.

Go to Preferences (button in top right corner), GUI, and scroll down to Ovide Smart Assist® mode and select SA-4, also enable “Write oled displays”.

---

## UNDERSTANDING VIDEO PROCESSING

Ovide Smart Assist 4 has 4 video processors in HD/2K mode and one in 4K. You can therefore have four independent video processed outputs and 4 live inputs routed to each of the 12 outputs.

Each processor can be fed either with independent inputs, the same input as another processor, provide a multiviewer including several inputs, or even 3D processed video.

You can set QTake® to have 1 to 4 processors available. The more processors you use, the more power you will need, and the lesser time the batteries will run.

To choose how many processors you want to use on a given project, in QTake®, go to FILE, open OUTPUT SETUP toolbar, and click on QOD resolution, there you will be able to choose how many SDI processors you want to use.

From V1.3, QTake will autodetect Smart Assist and change GUI accordingly. Please do not change it. If using a prior version or not detected, please manually change it.

Ovide Smart Assist 4® has a builtin router, independent of QTake®'s control of Videohub external router, that you can still use.

## STEP 1

In QTake®, open OUT toolbar and you will see a new toolbar with two modes of operation: quick and advanced.

## STEP 2

Quick mode lets you change outputs one by one in a fast mode of operation.



## STEP 3

Extended mode, including groups and presets.



## STEP 4

To toggle between toolbar modes, just press the double arrows at the end of the toolbar.

**STEP 4.1 QUICK MODE:** Just click one of the grey buttons to change the video feed of that output. This menu will pop up:

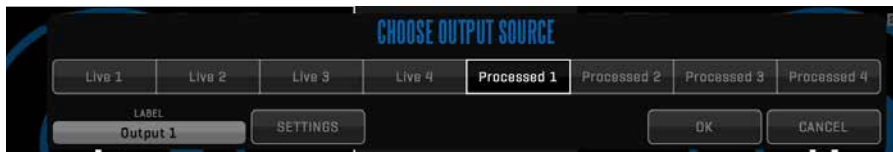

**SETTINGS OF PROCESSED MODE:** In simple mode, if a processor is chosen, click settings, or in advanced mode long click on a processor to choose what you want to see in that processor by clicking the SETTINGS button:



**STEP 4.2 ADVANCED MODE:** Here you can choose presets and groups just like you do in regular videohub remote on QTake® (refer to QTake®'s user manual). Labels will appear in rear OLED displays.up:

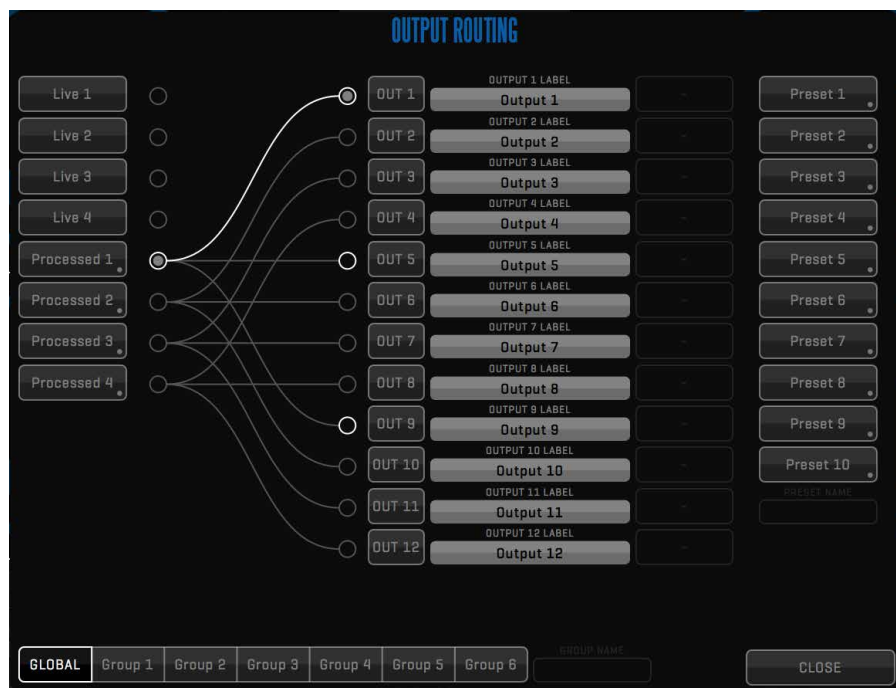

**IMPORTANT:** Please bear in mind that the buttons named 'Live' are just live feeds from input to output (ie: E-E), so image is totally unprocessed, no OSD, LUTs or FXs, no playback, no Composite is available. Image is sent 'as it is' straight to the output.



# ACCESSING SYSTEM'S RAM MODULES

If you need to access the RAM modules, they can be easily accessed:

## STEP 1

**IMPORTANT:** Completely turn off your Smart Assist using the rear button.

## STEP 2

Remove the two Philips screws at the sides of the rear XLR connectors.

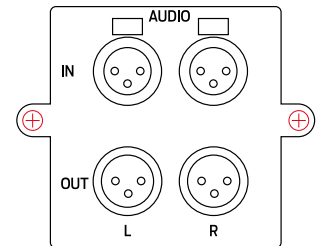

## STEP 3

Remove the flat ribbon cable taking note of the right orientation of the cable.

## STEP 4

Locate two grey levers on the right and left sides of the memory cradle. Push the two memory cage levers outward to release the memory cradle.

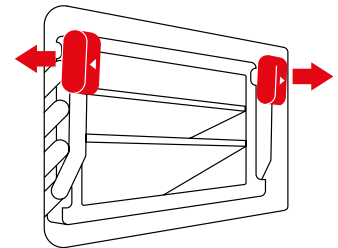

## STEP 5

Once the memory cradle is released, pull the memory cradle levers toward you, allowing access to each DIMM slot.

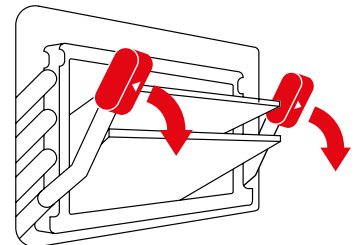

## STEP 6

Remove a DIMM by pulling the module straight up and out. Note the location of the notch on the bottom of the DIMM. When reinstalling DIMMs, the notch must be oriented correctly or the DIMM won't fully insert.

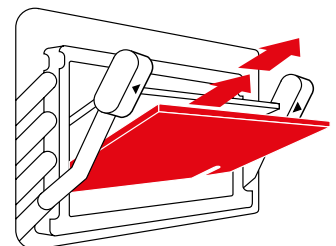

## STEP 7

Replace or install a DIMM by setting it down into the slot and pressing firmly until you feel the DIMM click into the slot.

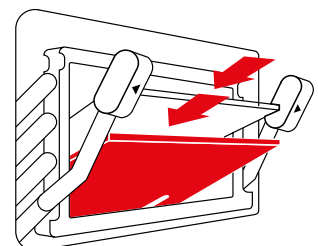

---

## STEP 8

Once you have all of your DIMMs installed, push the memory cradle levers back into the housing until they subtly click back into place.

---

## STEP 9

Please remember all modules have to be of exactly the same and they must be installed in pairs. If only two modules are installed, first module has to go in the lowest position, next one empty and second module on the third slot.

---

## STEP 10

Once the modules are inserted till the end, swing the cradle back to its original position and make sure it is locked with the grey clips.

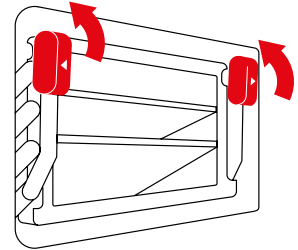

---

## STEP 11

Now connect the flat ribbon cable to the audio board, put the board back to its place and screw it.

---

You can change your internal video drive easily:

## STEP 1

**IMPORTANT:** Completely turn off your Smart Assist using the rear button.

## STEP 2

Underneath the screen you will see a dock for the drive.

Pull the little handle.

## STEP 3

Drive will slide out.

Now you can insert another drive: Please take care when inserting the drive and make sure hard drive upside is in the same side as the Smart Assist display (as opposed to back connector panel)

## STEP 4

Close the door until you hear a click.

Now you can turn on your system again.

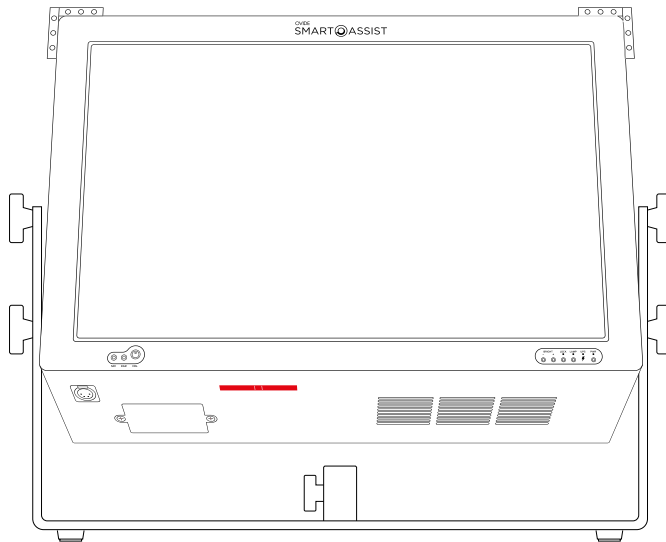
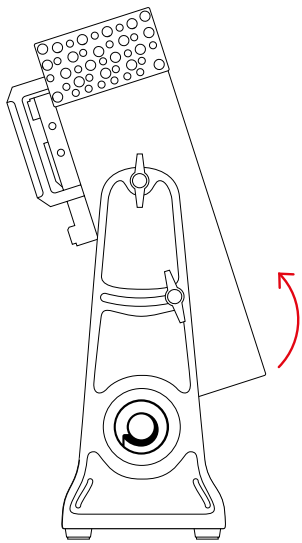

---

## OLED DISPLAYS NOT UPDATING OR EMPTY

Please check QTake preferences, under GUI settings if write OLED displays is enabled. Try also pressing the button by the OLED displays to see if they turn on.

---

## MISSING OSX DESKTOP

Please do not change mirroring settings in OSX System Preferences. If you accidentally changed or by any reason you loose your OSX main screen, press cmd+F1

---

## VIDEO INPUT/OUTPUT PROBLEMS

If QTake can't set your processors to a stable output or you have problems with your inputs, you can try doing a hardware reset of video i/o boards. To do so, you don't need to shut down the unit, just press brightness (-) and light buttons and hold them until front LEDs start lighting and scrolling. Release both buttons and all video boards will restart. You will momentarily loose your OSX/QTake local screen.

---

## HEADPHONE OUTPUT NOT WORKING OR LEVEL IS TOO LOW

1. Make sure that OSX setting for headphones is enabled and at maximum volume
2. In QTake, FILE room, talkback toolbar, make sure Headphones is selected for Output device and you have selected MAIN or MIX.
3. Make sure front volume knob is in the right position

---

## ECHO/DELAYED SOUND IN LIVE

If you hear echo, a second delayed audio or your live sound is dissorted, make sure you have muted audio of cameras 2 to 4. To do this, go to SHOOT, OPTIONS toolbar, and choose MUTE B (QTake HDx2) or MUTE B-D (QTake HDx4).